

SERIAL #:

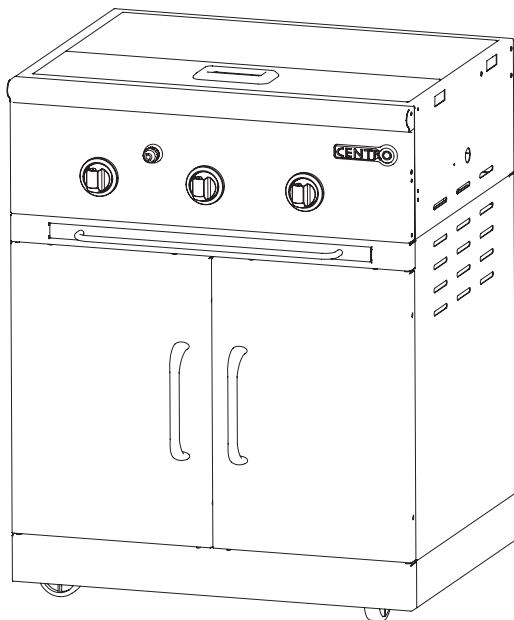

Outdoor Grilling System

SAFE USE, CARE AND ASSEMBLY MANUAL



3 YEAR LIMITED WARRANTY

85-1134-4 (PROPANE) (G41503)

Read and save this manual for future reference.
If pre-assembled, leave this manual with
unit for consumer's future reference.

For product inquiries, parts, warranty
and troubleshooting support, please call
1-877-707-5463

WARNING
Always cook with the lid open.
Lid should only be used for storage once
the unit has cooled down.

DANGER

If You Smell Gas

- 1. Shut off gas to the appliance.**
- 2. Extinguish any open flame.**
- 3. Open lid.**
- 4. If odor continues, keep away from the appliance and immediately call your gas supplier or your fire department.**

WARNING

- 1. Do not store or use gasoline or other flammable liquids or vapors in the vicinity of this or any other appliance.**
- 2. An LP cylinder not connected for use shall not be stored in the vicinity of this or any other appliance.**

WARNING

Failure to follow all of the manufacturer's instructions could result in hazardous fires, explosions, property damage, or serious personal injury or even death.

WARNING

Follow all leak check procedures carefully prior to operation of barbecue, even if barbecue was store assembled. Do not try to light this barbecue without reading the Lighting Instructions section of this manual.

**THIS BARBECUE IS FOR
OUTDOOR USE ONLY**

TABLE OF CONTENTS

Warranty	ii
Installation Information	1
Additional Warnings	1
Use of LP Gas Cylinder,	1-2
Transportation and Storage of the LP Cylinder, Filling the LP Cylinder	
Prior to Using the Grill	3
Safety Hose and Regulator	4
Safety Leak Testing	5
Lighting the Main burners.	6-7
Parts List and	8-9
Parts Diagram	
Assembly Instructions	10-13



WARRANTY

3 Year Limited Warranty

This Centro Barbecue carries a three year limited warranty against defects in manufacturing workmanship. This Limited Warranty is nontransferable and becomes void if used for commercial or rental purposes. This warranty applies only when grill is used in Canada. The bill of sale or a copy will be required together with the serial number and model number when making any warranty claims from Trileaf Distribution. Trileaf Distribution reserves the right to have its representatives inspect any product or part prior to honouring any warranty claim. Trileaf Distribution shall not be liable for any transportation charges, shipping and handling charges, or labour costs. This warranty is for replacement of defective parts only. The Manufacturer will not be responsible for incidental or consequential damages or any labor cost. Inability to provide proof of purchase, or if warranty coverage has expired, any request for parts will be subject to parts, shipping and handling fees. This limited warranty does not cover damage due to chipping and scratching of porcelain or painted surfaces including Cooking grates, nor does it cover corrosion or discolouration due to misuse, lack of maintenance, grease fires, hostile environments, accidents, alterations, abuse or neglect, improper installation and failure to read and/or abide by any product warnings. This limited warranty does not cover any damage sustained during removal or storage of this BBQ. Part failure due to lack of cleaning and maintenance, or use of improper cleaning products such as Oven Cleaner will not be covered under this manufacturers warranty. This limited warranty does not cover any scratches or dents, corrosion or discolouring caused by heat, abrasive or chemical cleaners. Parts installed from other manufactures will nullify this warranty.

3 Year Limited Warranty

The following functional parts are included under this warranty: Burners, manifold assembly and carryover assembly.

1 Year Limited Warranty

For one year from the date of original retail purchase Trileaf Distributions will replace any grill part that fails or is found to be defective to the degree of non-performance under normal household use, during the limited warranty period. Trileaf Distributions Ltd. are not responsible for any grill damage sustained during moving, storage, assembling or cleaning. Unless otherwise noted, as in above limitations, all components are covered for a period of one year.

IMPORTANT: Should you have difficulty operating this product, or have a part that has become defective within the stated warranty period, DO NOT RETURN TO STORE. STORES DO NOT STOCK REPLACEMENT PARTS AND ARE UNABLE TO HELP WITH TROUBLESHOOTING ADVICE. PLEASE CALL 1-877-707-5463. Have your Proff of purchase, serial number and model number available so that the customer support agent can be of assistance.

Purchaser: By accepting delivery of this Barbecue the purchaser, hereby accepts the foregoing and expressly waives any other remedy and damages, direct, indirect, and consequential.

INSTALLATION INFORMATION

The installation of this appliance must be in accordance with all local codes, or in the absence of local codes:

- Canadian installation must conform to the current national standards, which at this time are CAN/CGA-B149.1/2-Natural Gas/Propane installation code.
-

ADDITIONAL WARNINGS

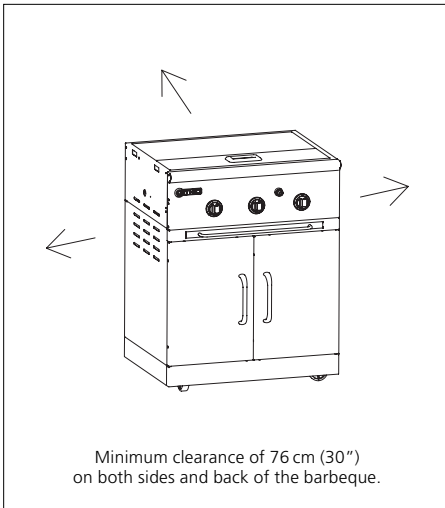

Drawing A

Minimum clearance to adjacent combustible materials:

- **76 cm (30")** from furthest protruding edge on side of barbecue.
- **76 cm (30")** from furthest protruding edge on back of barbecue.

See Drawing A

- Always keep the area around this barbecue clean and clear of any and all combustible materials such as gasoline or other inflammable liquids, paper or oily rags.
 - **Do not** operate this barbecue under any overhanging or unprotected construction.
 - Remember this barbecue is for **outdoor use only** and is **not** for use on any boat or recreational vehicle.
 - Use this barbecue outdoors in a well-ventilated area and at least 3 m (10') from any dwelling or other building.
 - **Do not** use in garages, or any other enclosed area.
 - **Do not** leave your barbecue unattended while in operation.
 - **Do not** obstruct the flow of combustion and ventilation air to the barbecue.
 - **Do not** use while under the influence of drugs or alcohol.
 - **Do not** store any spare L.P. (propane) cylinders, full or empty, under or near your barbecue.
 - **Do not** allow children or pets to play anywhere near the barbecue.
-

USE OF LP GAS CYLINDER

Self-contained Propane Gas System

The self-contained (propane) gas system barbecue is designed to be used with only a 9.1 kg (20 lb) propane cylinder equipped with a type-1 cylinder valve. This barbecue **cannot** be connected to an existing #510 P.O.L. type valve cylinder (which has left-handed threads).

Do not connect to a propane gas cylinder exceeding 9.1kg capacity or use a cylinder with any other type of cylinder valve connection device.

The Type-1 valve can easily be recognized by the large external thread on the outside of the valve. Older existing valves **do not** have this outer external thread. Any attempt to connect a regulator to any connector other than the mating Type-1 connector (which comes with a large, black coupling nut such as the #510 P.O.L.) could result in fires, injuries or property damage, and could reduce the effectiveness of the important safety features built into the Type-1 system. Also connecting the #510 P.O.L. fitting to the cylinder will negate the flow control and the temperature shut-off features built into the new Type-1 connection system.

- The cylinder should not exceed 472 mm (18 1/2") in height and 317 mm (12 1/2") in diameter.

When purchasing a cylinder for your barbecue, it must be constructed and marked as meeting the specifications of:

- Canada: Transport Canada.

The Cylinder must also be equipped with:

- A shut-off valve with a correct cylinder valve outlet as specified in current standards.
 - Canada: CAN/CGA 1.6g-M97 Outdoor Gas Grilles.
 - a) A safety relief valve with direct connection to the vapour space of the cylinder.
 - b) A collar to protect the tank shut-off valve.
 - c) A device for vapour withdrawal.
 - d) A ring on the bottom to secure the tank to its support assembly.
- Always turn off the cylinder valve completely when the barbecue is not in use.
 - Always handle the tank valve with utmost care.
 - Never connect an unregulated L.P. gas cylinder to the barbecue.
 - Always keep the cylinder, in use, securely fastened in an upright position.
 - Never store a spare cylinder, empty or full, near or under the barbecue when in operation.
 - Never expose the cylinders to direct sunlight or excessive heat.
 - Never insert any kind of object into the valve outlet as this may damage the backcheck; a backcheck that is damaged can leak, and a leaking propane cylinder can result in fires or explosions, property damage, severe injuries or death.

**TRANSPORTATION
AND STORAGE
OF THE LP CYLINDER**

The propane cylinder is totally safe when handled properly, but if misused, the result could be an explosion or fire resulting in serious personal injury and/or property damage.

To Avoid Unnecessary Risks

- Always recap the cylinder with the cap provided when not connected to the barbecue.
- **Do not** store the cylinder in any enclosed area such as a garage, and make sure the storage area has lots of ventilation.
- **Do not** store the cylinder near any appliances, or in any areas that may become hot, such as the trunk of a vehicle.
- Make sure the cylinder is out of reach of children.
- When transporting or storing the cylinder, make sure it is in an upright position and not on its side.
- **Do not** smoke around the cylinder, especially when transporting it in a vehicle.

**FILLING THE
LP CYLINDER**

The cylinder must be filled prior to use and must have the air purged. For safety, follow these instructions when having your cylinder filled:

- Have only your local qualified LP gas dealer fill or repair a cylinder.
- **Do not** overfill the cylinder beyond the safe 80% fill level.
- Make sure the dealer tests and checks the cylinder for leaks after filling.

WARNING

**If the above instructions are not completely adhered to,
it could cause a fire/explosion, resulting in death or serious injury,
or property damage.**

PRIOR TO USING

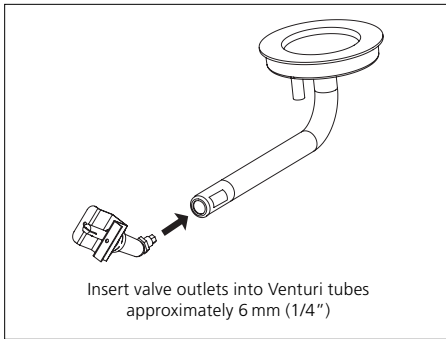

Drawing E

Do not use your barbecue until you have carefully read and fully understand all the information in this manual. Please ensure the following:

- Your barbecue is properly assembled.
- There are no leaks in the system (see "Leak Test").
- The burner is properly assembled, with the Venturi tubes seated over the valve outlets (Drawing E) and that there is nothing blocking the Venturi tubes (Drawing F).
- Ensure that all power cords and/or gas supply hoses will not touch or be near surfaces that will get hot.
- The barbecue is in a safe location (see Installation).

Ensure that the valve outlets (orifices) are assembled into the Venturi tubes approximately 6 mm (1/4") and that the valve outlets and Venturi tubes are approximately parallel to the bottom of the lower body.

WARNING

Natural Hazards Insects and Spiders

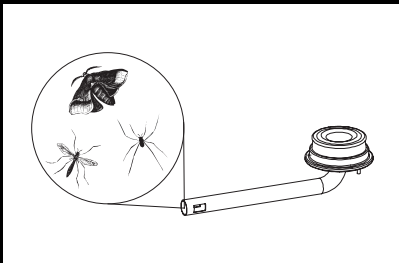

Drawing F

During shipment or storage, it's possible that small insects like spiders could find their way into the Venturi tubes and nest or make webs. This could block the flow of gas through the Venturi tube causing a smoky yellowish flame, or prevent a burner from lighting. It could even cause the gas to burn outside the Venturi tube, which could seriously damage your barbecue. If these occur, turn off the gas flow and wait for the barbecue to cool down. When the barbecue has cooled, remove the burner and clean out the Venturi tubes with a brush or pipe cleaner. Replace the burner and ensure that the Venturi tubes are seated over the orifice located on the gas valves. Cleaning the Venturi tubes should be conducted periodically, especially at the start of the season.

Note: Damage resulting from blocked Venturi tubes is not covered under the warranty.

Orifice Size: The orifice, in conjunction with the control valve, acts to regulate and restrict the amount of gas delivered to the burner. The hole size in the orifice varies by the gas supply pressure and by the BTU rating of the burner. Grills equipped for LP gas operate at a much higher gas pressure and therefore have a smaller size orifice.

Hose and Regulator Inspection

Adjustment: The regulator is factory set at a specified outlet pressure of 11" of water column and is generally factory sealed and not adjustable. Do not try to adjust. The regulator can be checked by measuring the pressure with a manometer.

Vent Hole: There is a vent hole on top of the regulator. Check that it is clear of dirt and debris. If the hole is plugged, erratic and dangerous burning may result.

O-ring Seal: Before attaching the regulator to the cylinder, inspect the rubber O-ring on the P.O.L. fitting. Do not operate the grill if the O-ring is damaged or missing. Seal damage is common and we recommend replacement of the seal when the burner is replaced or when the seal is damaged. Cracks, splits or distortion will allow gas to escape. Additionally, the seal should be soft, pliable, and protrude slightly from the brass P.O.L. valve.

Chew Marks: The hose should be kept clean of grease and food drippings which attract squirrels and other animals. The animals will often eat the drippings on the hose and chew into the hose lining trying to get the last taste. Try cleaning the hose with an ammonia cleaner solution to minimize the attraction.

SAFETY HOSE AND REGULATOR

Propane Gas Models: Your barbecue is designed to operate on L.P. (Propane) gas at a pressure of 2.74 Kpa (11" water column). A regulator preset to this pressure is supplied with the barbecue and must be used.

This regulator is equipped with the Type-1 quick-closing connecting system, which incorporates these safety features:

- Will not allow gas to flow until a positive seal has been made.
- Has a thermal component that will automatically shut off the flow of gas between 115-150°C (240-300°F).
- Has a flow limiting feature, which will restrict the flow of gas to 10 cubic feet/hour.

Should the large, black thermal-sensitive coupling nut be exposed to any extreme temperatures above 115°C it will soften and allow the regulator probe to disengage from the valve, and will shut off the gas. Should this occur, **do not** try to reconnect the nut; instead replace the whole regulator assembly with a new one (see the attached parts listing for details). The regulator probe also contains a flow-sensitive feature, which limits the flow of gas to 10 cubic feet/hour, in the event of a regulator malfunction or hose leak. If the flow control feature is activated, the cause of this excessive gas flow should be investigated and corrected before using the barbecue again.

Note: Improperly lighting the barbecue can activate the flow control feature, resulting in lower heat output. If this occurs, the re-flow feature must be reset by turning all the burner controls and the cylinder valve off. Wait at least 30 seconds before slowly turning on the cylinder valve, and then after another 5 seconds turn the burner valve on and light the barbecue.

- Never connect this barbecue to an unregulated propane gas supply, or to another kind of gas. **Do not** alter or change the hose or regulator in any way.
- Visually inspect the whole hose assembly before each use for evidence of wear or damage such as cracks, burns, or cuts. If any damage is found, replace the assembly before using the barbecue. Use only the recommended replacement hose.
- To avoid possible damage to the hose, **do not** allow any grease or other hot materials to fall on the hose, and make sure the hose does not contact any hot surfaces of the barbecue.
- The connection fitting must be protected when it's disconnected from the cylinder. **Do not** allow the fitting to bump or drag on the ground as nicks and scratches could help create a leak when connecting back to the cylinder.
- It is important to do the "Leak Test" procedure every time a cylinder is refilled or any of the components are changed, and especially at the beginning of a new season.

To Reset The Gas Regulator Safety Device

1. Close the LP (propane) tank valve.
2. Turn all burner control knobs to the OFF position.
3. Disconnect the regulator from the LP tank.
4. Open the grill lid.
5. Open all of the control knobs to the high position.
6. Wait 2 minutes.
7. Close all of the control knobs.
8. Re-connect the regulator to the LP tank. Test for leaks.
9. With lid open, push in and turn the centre control knob to the HIGH position. Wait 5 seconds and then ignite the grill by pressing the Electronic Ignitor.
10. Once lit, close the grill lid.
11. Wait for 10 to 15 minutes for the Barbecue to preheat.

ATTENTION: Proper start up and shut down procedures should be followed to avoid regulator safety device activation.

WARNING

If the heat output is too low, the flow control feature may have been activated by a gas leak. If so, turn off the burner valve and cylinder valve, and perform the "Leak Test". If there aren't any leaks, re-light the burner.

SAFETY

LEAK TESTING

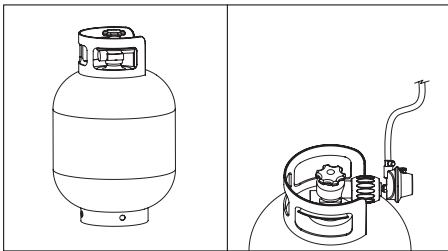

Drawing B

Drawing C

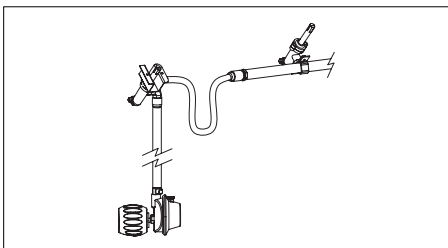

Drawing D

Perform a "Leak Test"

- Before lighting your barbecue for the first time.
- Every time the cylinder is refilled, or any component is replaced.
- At least once every year, preferably at the start of the season.

The "Leak Test" must be done outdoors, away from heat, open flames and flammable liquids. **Do not** smoke while performing the test. Use only a mixture of 50/50 liquid soap and water for leak testing. Never use a match or open flame.

The Following Must Be Checked

- The tank valve including the threads into the tank (Drawing C).
- All tank welds (Drawing B).
- Regulator fittings and tank connections (Drawing C).
- All hose connections (Drawing D).
- **With a newly filled and tested propane tank attached to the barbecue and all the barbecue controls turned "OFF", slowly open the cylinder valve one full turn.**
- **Using a brush and soap, soak all the connections and components listed above and shown in drawings B, C, D.**
- **Look carefully for bubbles forming, which is an indication of leaking gas.**
- **Tighten the connections at the bubbled areas until re-testing shows no indication of any leaks (shut off cylinder while correcting any leaks).**
- Shut off the cylinder valve and ensure all control valves are off.
- **Do not** use the barbecue if any leaks cannot be stopped. Turn off the gas cylinder valve, remove the gas cylinder and seek assistance from a qualified gas appliance service mechanic or gas dealer.

LIGHTING THE GRILL

Make Sure you have followed all the safety checks, procedures and instructions indicated in the previous section, before attempting to light the grill.

Lighting The Main Burners

1. Always open the hood completely and always inspect the grill and burners to confirm that all components are properly positioned before lighting the main burners.

WARNING

Never stand with your head directly over the Barbecue when preparing to light the main burners, to prevent possible bodily injury.

2. Always confirm that all of the burner control knobs are in the OFF position before opening the gas supply.
3. Slowly turn on the propane gas supply valve at the tank 1-2 turns.
4. Wait approximately 5 seconds before turning the center burner control to the HIGH position by pushing down and turning it counter-clockwise. This procedure allows pressure to stabilize, and prevents the flow limiting feature from being activated.
5. Immediately press the Electronic Ignitor. As you press the ignitor you will hear a continuous clicking sound as the module generates an ignition spark to the burner. The selected burner should light within 5 seconds. Light the remaining burners by pushing in and turning the left and right control knobs.

WARNING

IF THE SELECTED BURNER DOES NOT LIGHT, immediately turn the burner control knob and cylinder valve to the OFF position, to prevent gas buildup. Wait five minutes for the gas to clear and then repeat the preceding starting procedure. IF the burner will not light when using the Ignitor, follow the match lighting instructions.

6. Confirm that the burner is properly lit. If the flame pattern is other than normal, consult the Troubleshooting Guide for corrective action.
7. Always preheat the Barbecue before starting to cook. Light all burners and adjust them to the HIGH position for 5-10 minutes. Before placing any food on the Barbecue, clean the cooking grids with a Porcelain cleaning brush.
8. Adjust the controls to a medium setting for most cooking requirements. A light coating of cooking oil on the cooking grids, before heating the grill, will prevent foods from sticking to the grill.

Turning The Burners Off

1. Always turn the burner control knobs to the off position when cooking has been completed.
2. Promptly turn OFF the gas supply valve at the propane cylinder.
3. Close the hood of the grill.

Match Lighting The Main Burners

1. Always open the hood completely and inspect the grill and burners to confirm that all components are properly positioned, before lighting the main burners.

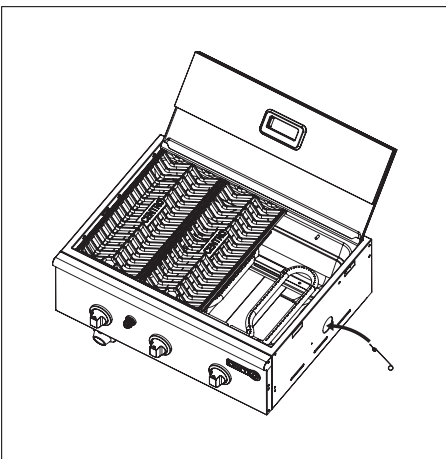

Drawing G

WARNING

Never stand with your head directly over the Barbecue when preparing to light the main burners, to prevent possible bodily injury.

2. Always confirm that all of the burner control knobs are in the OFF position before opening the gas supply.
3. Always turn on the propane gas supply valve at the tank (1-2 turns).
4. Insert a lit match or a butane lighter into the match lighting hole located on the lower left hand side of the firebox (Drawing G).
5. Turn the left burner control knob to the HIGH position by pushing on the knob and turning it counter-clockwise.

**PARTS LISTING FOR
85-1134-4 (PROPANE)
(G41503)**

Item No.	Quantity	Specification	Part No.
A	1	Burner Box Assy	
AA	1	Lid Assy	G415-2400-01
AB	1	Rotary Axes	G415-0002-01
AC	1	Pull, Lid Assy	G415-0031-01
AD	2	Cooking Grate, Burner Box	G415-0012-01
AE	1	Cooking Griddle	G415-0013-01
AF	1	Grease Cup	G415-0029-01
AG	3	Flame Tamer	G415-0011-01
AH	1	Handle F/Lid	G415-0001-01
BA	1	Burner Box Weldment	G415-3000-01
BB	1	Burner Box Frame	G415-0007-01
BC	2	Main Burner Assy-A	G607-0700-01
BD	1	Main Burner Assy-B	G502-1800-01
BE	1	Burner Brace	G415-0300-01
BF	1	Manifold Assy	G415-4200-01
BG	1	Regulator	G419-0013-01
BH	1	Electronic Ignition Kit	G415-0005-01
BI	1	Control Panel	G415-0037-01
BJ	3	Control Knob Bezel	G419-0006-01
BK	3	Control Knob	G413-0020-01
BL	1	Rear Panel, Burner Box	G415-0010-01
BM	1	Cart Handle	A011-0016-01
CA	1	Left Side Panel, Cart	G415-0500-01
CB	1	Right Side Panel, Cart	G415-0600-01
CC	1	Upper Brace	G415-6000-01
CD	1	Upper Back Brace	G415-0020-01
CE	1	Grease Tray	G415-0022-01
CF	1	Grease Tray Front Panel	G415-0023-01
CG	1	Handle, Grease Tray	G415-0024-01
CH	1	Left Rail, Grease Tray	G607-0033-01
CI	1	Right Rail, Grease Tray	G607-0034-01
CJ	1	Tank Exclusion, Wire Frame	G502-0069-01
CK	1	Bottom Shelf	G415-0400-01
CL	1	Bottom Rail	G415-0019-01
CM	2	Door Handle	G413-0016-01
CN	1	Left Door Assy	G415-8000-01
CO	1	Right Door Assy	G415-9000-01
CP	2	Caster Assy W/ Lock	G401-0061-01
CQ	2	Caster Assy	G606-0027-01
CR	1	Hardware Pack	G415-B003-01
CS	1	Manual	G415-M003-01

85-1134-4 (PROPANE) (G41503)

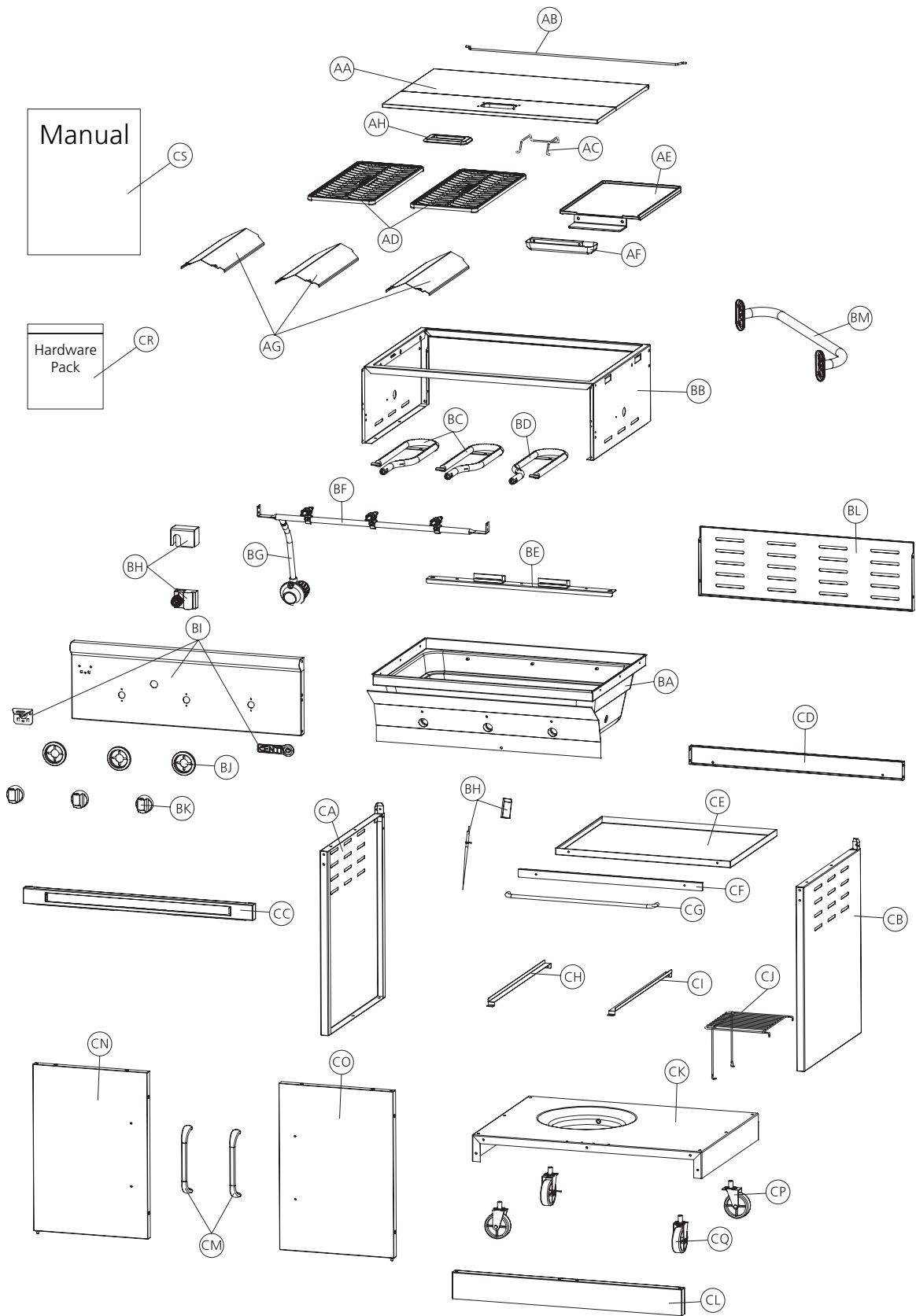

ASSEMBLY INSTRUCTIONS

Tools Needed for Assembly

- #2 Phillips® screwdriver
- Pliers
- 1/4" slotted screwdriver
- Rubber mallet
- Adjustable wrench

Before assembling the barbecue, read these instructions carefully. Assemble the barbecue on a flat, clean surface. Grill is heavy. You should have two people assemble the barbecue together.

Notes: Do not fully tighten all the nuts during this initial stage.

Caution: Sheet metal can cause injury. Wear gloves when installing the grill. Use care when assembling.

Hardware Pack List

No.	Description	Part Number	Quantity
1	1/4"x13mm Screw	20120-13013-250	10
2	Ø7 Lock Washer	41400-07000-250	10
3	Ø7 Washer	40300-07000-250	10
4	1/4"-20UNC Nut	30220-13000-250	6
5	NO.10 x 10 Screw	20124-10010-250	14
6	Ø5 Lock Washer	41400-05000-250	14
7	Ø5 Washer	40300-05000-250	14
8	AA-Battery	G610-0028-9000	1
9	Wrench	G413-0032-9082	1
10	ST4.2X10 Tapping Screw	22500-42010-137	2
11	NO.8-32UNC x10 Screw	20132-08010-250	4
12	Ø4 Lock Washer	41400-04000-250	4
13	Ø4 Washer	40300-04000-250	4

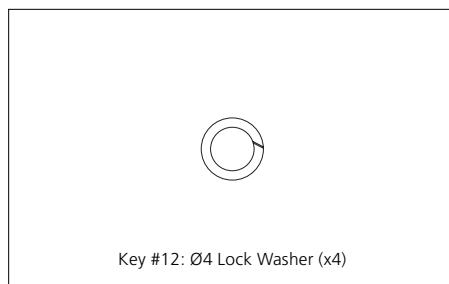
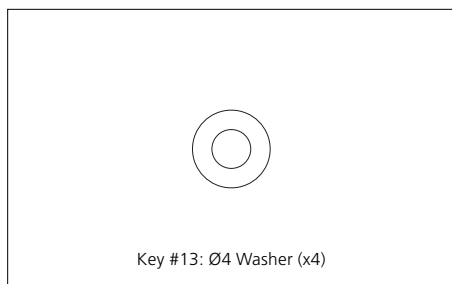
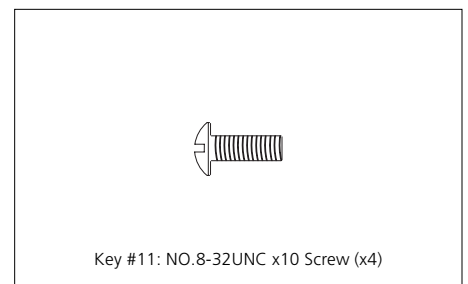
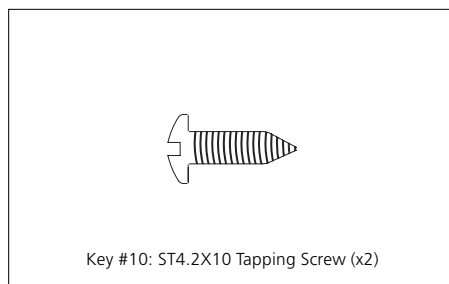
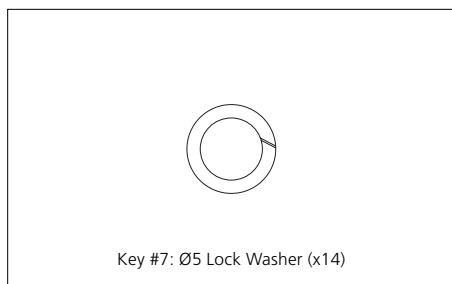
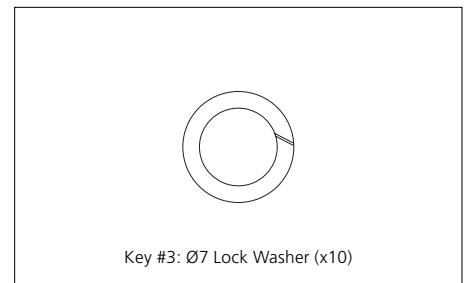
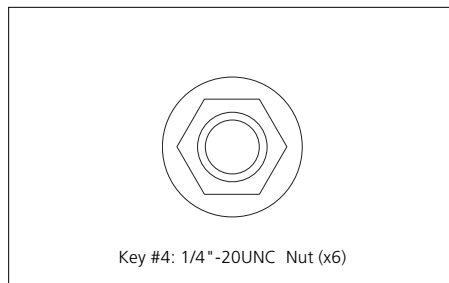
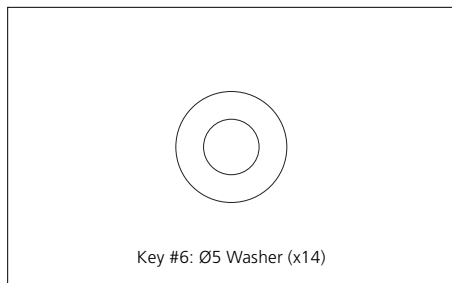
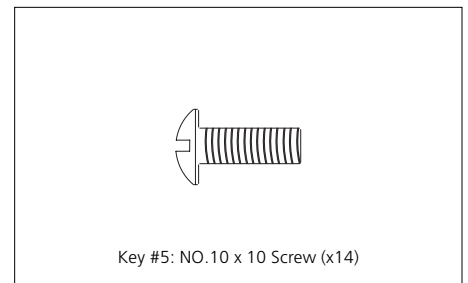
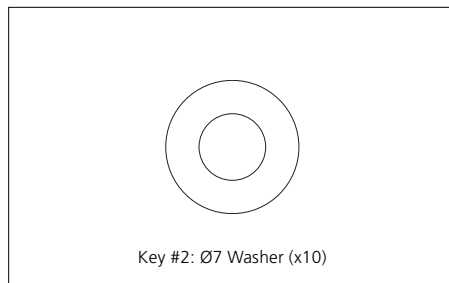
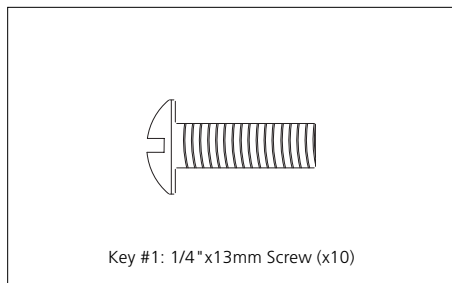

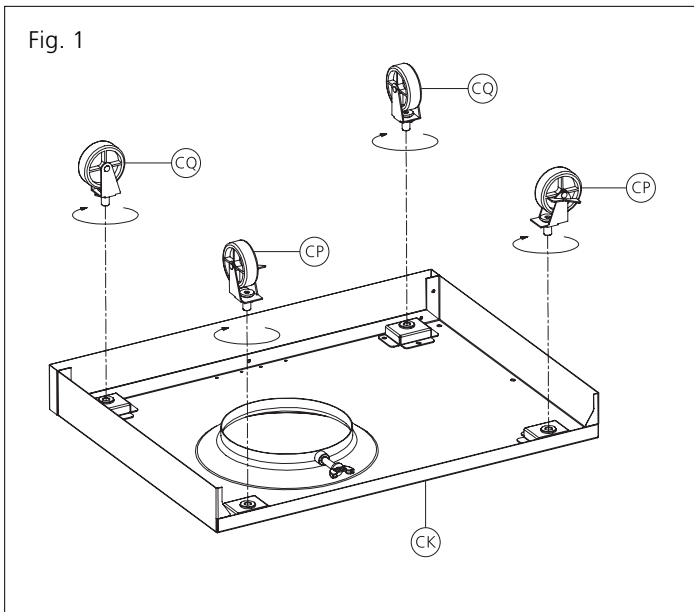

1

Attach two front casters (CQ) and two back casters with lock (CP) to the bottom shelf (CK) by using the provided wrench 9.

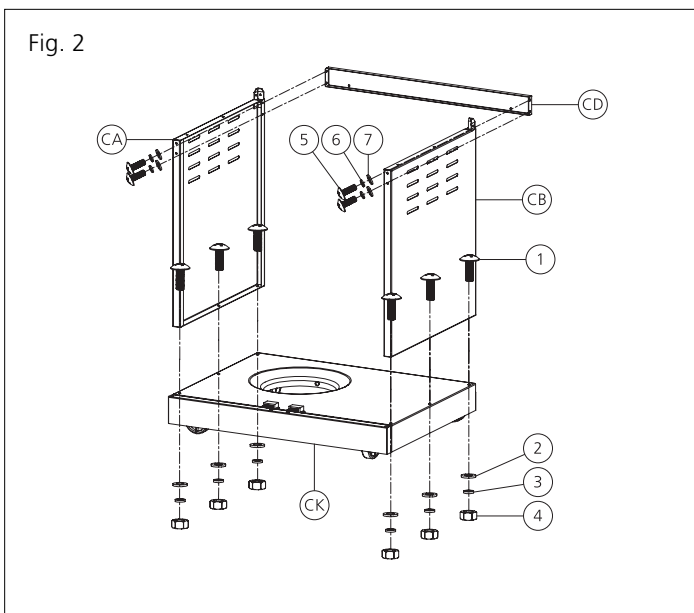

2

Assemble the left and right cart side panel (CA & CB) to the bottom shelf (CK) as shown by using hardware 1, 2, 3, and 4 (x6).

Assemble the upper back brace (CD) to both cart side panels (CA & CB) as shown by using hardware 5, 6, and 7 (x4).

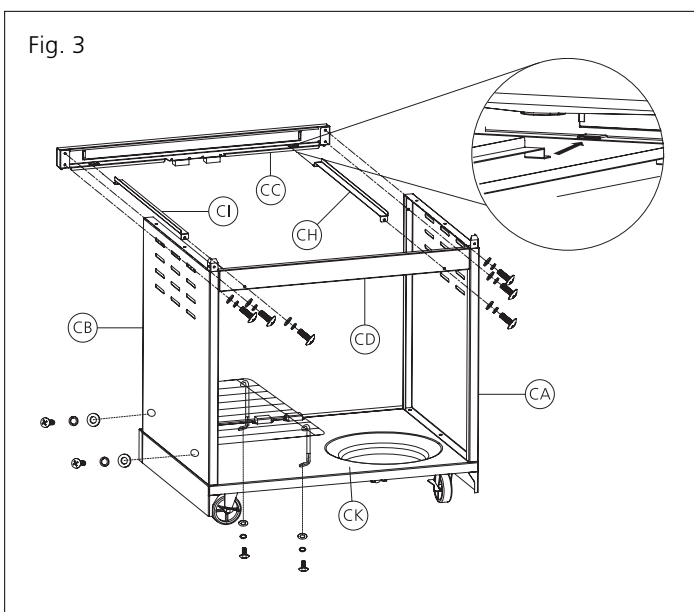

3

Insert the left and right grease tray rail (CH & CI) to the holder of the upper brace (CC) as shown.

Assemble the upper brace (CC) together with both grease tray rails (CH & CI) to both side panels (CA & CB) by using hardware 5, 6, and 7 (x4). Make sure to assemble both grease tray rails (CH & CI) to the upper back brace (CD) by using hardware 10 (x2). Assemble the wire flame to the right cart side panel (CB) and bottom shelf (CK) by using #11, #12 and #13 (x4).

Fig. 4

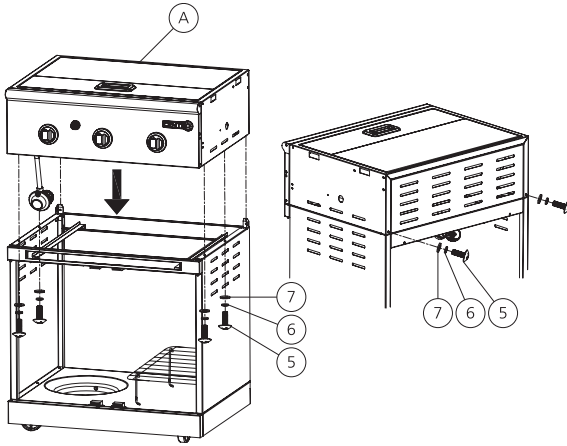

4

Affix the Burner Box assembly (A) to the Cart assembly as shown by using hardware 5, 6, and 7 (x4).

Tighten the burner box assembly to the cart assembly from the rear using hardware 5, 6, and 7 (x2).

Fig. 5

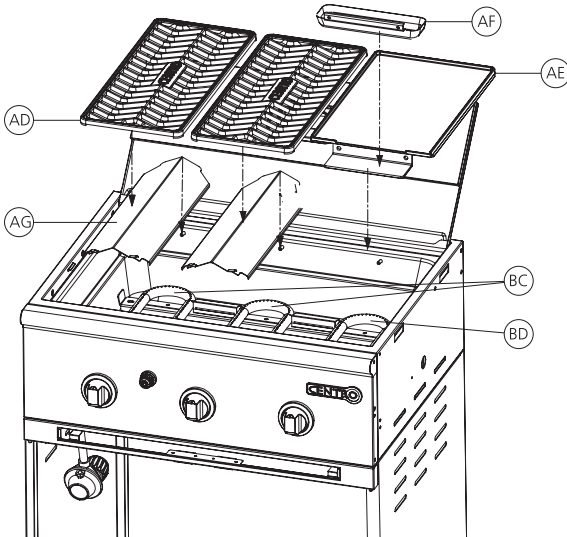

5

Insert the flame tamers (AE) into the burner box above the burners (BC). Place cooking grates (AD) or Griddle (AE) and grease cup (AG) in position as shown.

Fig. 6

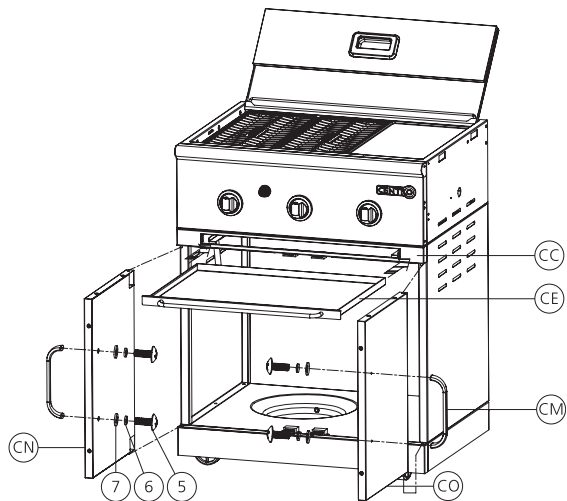

6

Insert the grease tray (CE) into the upper brace (CC).

Assemble door handles (CM) to both doors (CN & CO) by using hardware which are removed from door handle.

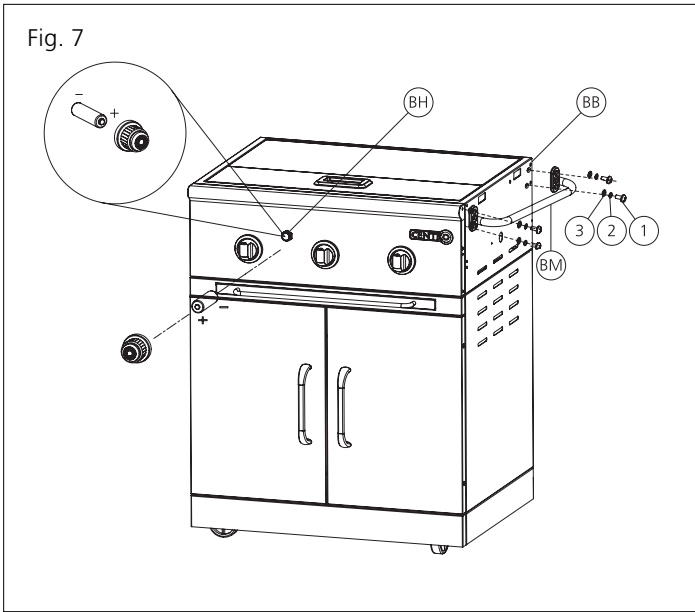

7

Unscrew the igniter cap and place AA batteries provided into igniter (BH) with positive end (+) facing outward. Screw igniter cap into igniter as shown.

Assemble the cart handle (BM) to the burner box frame (BB) by using hardware 1, 2, and 3 (x4).

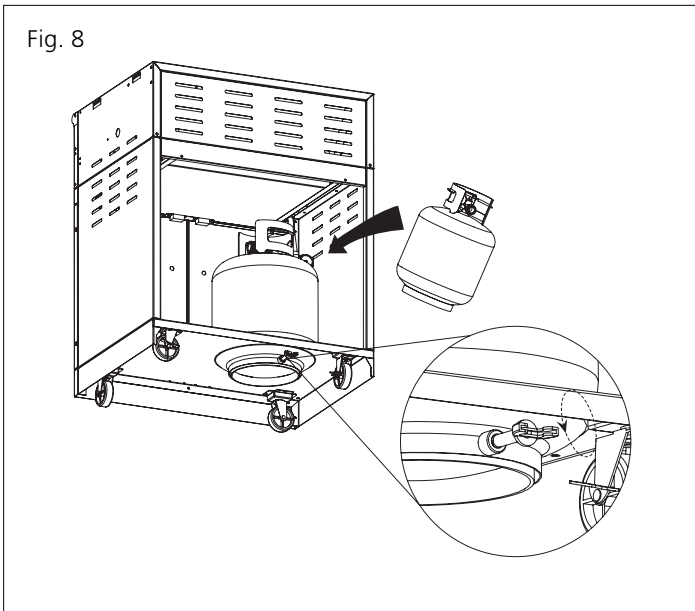

8

For propane model only

Secure 20lb propane tank onto the bottom shelf of the cart as shown, attach the regulator valve to 20lb propane tank.

WARNING

Do not store your extra propane tank within the enclosed storage cart.

DISTRIBUTOR

Trileaf Distribution Trifeuil
Toronto, Canada
M4S 2B8

